

未注公差/General tolerances (mm)													0.1/10 ±2'
0	>3	>6	>10	>18	>30	>50	>80	>120	>180	>250	>315	>400	
~ 3	~ 6	~ 10	~ 18	~ 30	~ 50	~ 80	~ 120	~ 180	~ 250	~ 315	~ 400	~ 500	>500
±0.12	±0.18	±0.22	±0.26	±0.31	±0.37	±0.57	±0.80	±0.93	±1.05	±1.15	±1.60	±2.20	±2.50

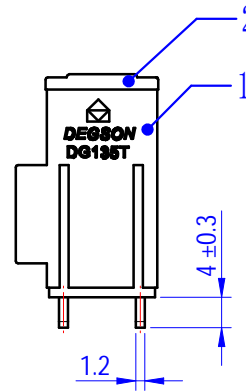

ITEM	NAME OF PART	MATERIAL	NOTES
5	pin header	Copper	Sn Plated
4	Cage	Copper alloy	M4/Ni Plated
3	Screw	Steel	M4/Zn Plated
2	Cover	PBT	UL94V-0
1	Housing	PBT	UL94V-0

UL 标准/UL Standard:	B	C	D
额定电压/电流/Rated Voltage(V)/Current(A)	300/52	300/52	600/5
IEC 标准/IEC Standard:			
过压类别/Ovoltage Category/污染等级/Pollution Degree	III/2		
额定电压/电流/Rated Voltage(V)/Current(A)	750/57		
工频耐压/Withstanding voltage	AC3000V 1Mn		
螺丝扭矩/Torque Tightening(N·m/Lb.in)	M4, 1.2/10.5		
线径范围(硬线和软线)/Wire Range(rigid and flexible)(AWG mm <sup>2</sup> )	20- 6/ 4- 10		
间距/Pitch(mm)/线数范围/Poles	10.16/N= 02- 12P		
剥线长度/Stripping length(mm)	11- 12		
使用温度范围/Operating temperature(°C)	-30- + 120		
符合 RoHS 环保要求/Conform to RoHS	Yes		

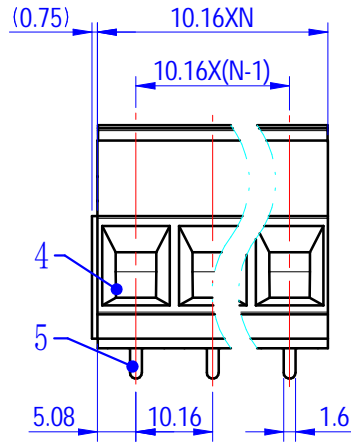
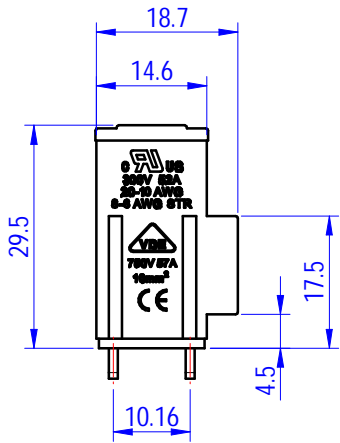
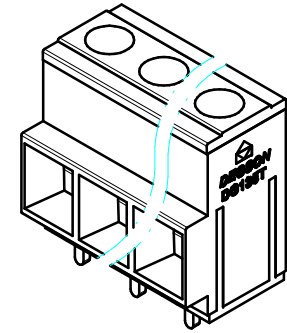
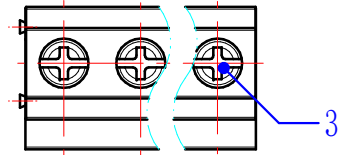
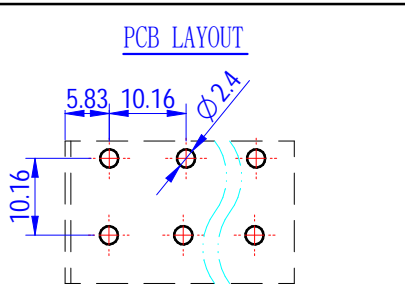

**DEGSON**

APPD: 兰春华 2022.11.23  
 CHKD: 陈招 2022.11.23  
 DRFT: 龚徐涛 2022.11.23

MATERIAL: SURFACE/COLOR:  
 MAT NO./REV: / MAT STATUS: 批量

NAME: DG135T-10.16-XXP-1Y-00A&Z(H)

DRAWING NO. 200031772 TYPE CUSTOMER DRAWING DRAWING STATUS 已发布 SCALE 1:1 SHEET 1/1

REV	ECN	DESCRIPTION	DRFT	DATE
01		修改U1刻字	龚徐涛	2022.11.23

Transfer or duplication of this document as well as the utilization or communication of its contents are prohibited unless authorized in general. Violations will be treated for compensation. All rights reserved for patent, utility model or design registrations. 除专利、实用新型、外观设计、软件著作权、集成电路布图设计、商标、印刷、注册商标外，其他内容均保留所有权利。